

AS 5 ILLUMINATED SPST ROCKER SWITCH

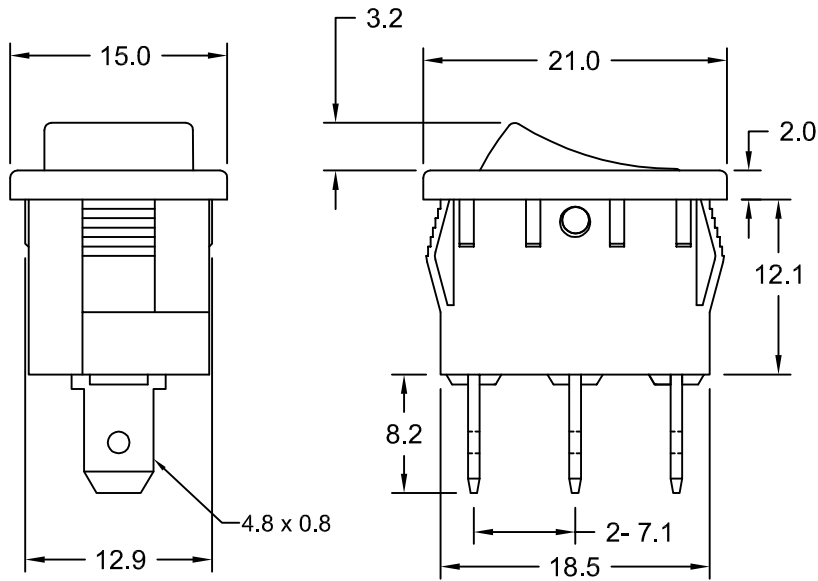

SPST Illuminated Rocker Switch Electrical Circuit Diagram

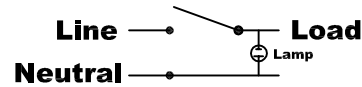

Approvals

CE - As per IEC / EN 61058 - 1

Reference Standards : IEC / EN 61058 - 1
UL - 1054

Body Colour

Black
White
Grey

Rocker Colour

Red Green
Amber Blue

MATERIAL OF CONSTRUCTION

BODY : Nylon 66 (Unfilled)
Flammability UL 94 V-2
ROCKER : Polycarbonate
Flammability UL 94 V-2
CONTACTS : Silver / Silver Alloy
Copper
TERMINALS : Copper / Copper Alloy
SPRING : Stainless Steel

RoHS Compliant

PANEL CUT-OUT SIZE

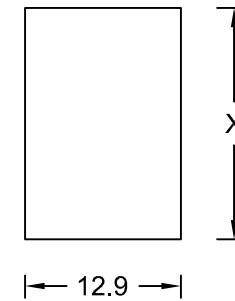

BEZEL

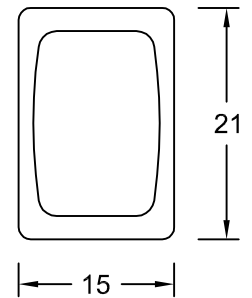

DIMENSIONS FOR SNAP - IN MOUNTING

PANEL THICKNESS

0.75 - 1.25
1.25 - 2.00
2.00 - 3.00

DIMENSION X

19.2
19.4
19.8

* Panel Cut-outs must be punched in the direction of insertion

PRINTING OPTIONS

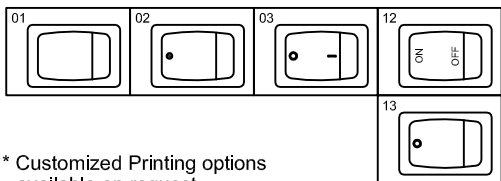

* Customized Printing options available on request

RATING

2 Amp, 250V AC
3 Amp, 250V AC
6 Amp, 250V AC
10 Amp, 250V AC

Astron Switch Craft